

## Unpacking

Before you begin using the device, please check the version you obtained and ensure that the following items are included in the shipped box:

### Mainframe Accessories :

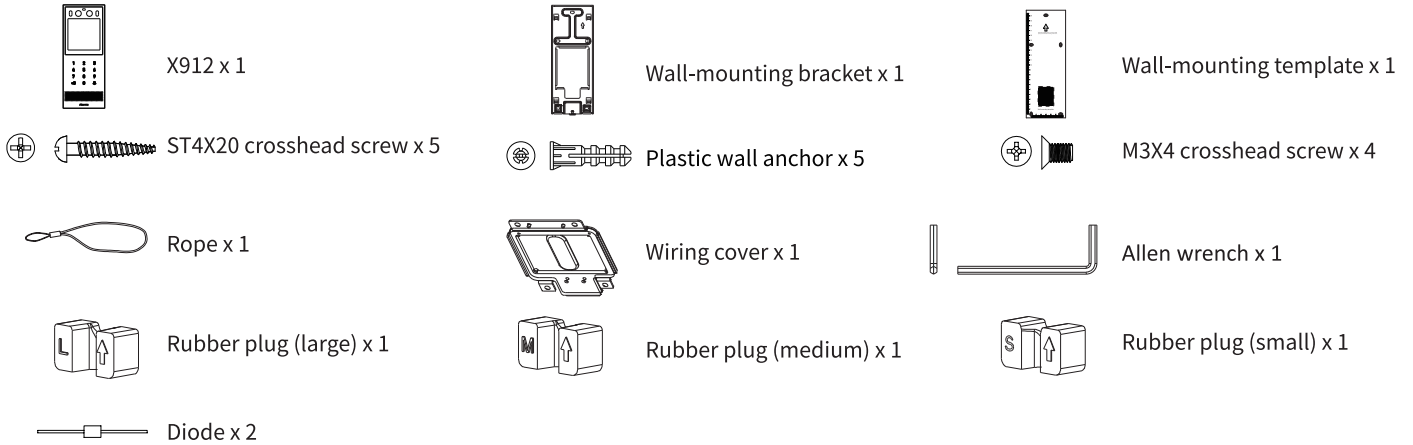

## Product Overview

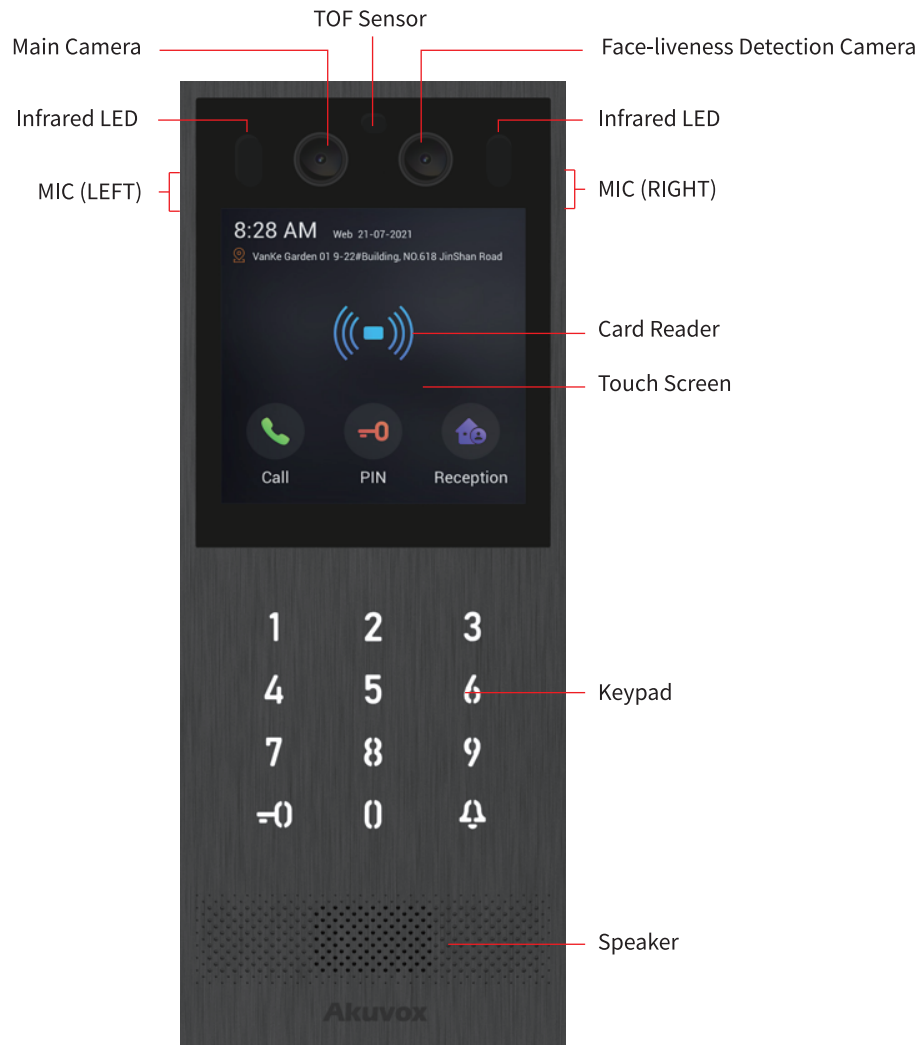

X912

## Installation Environment

Please do not place device under direct sunlight.

If installing the device indoors, please keep device at least 2 meters away from light, and at least 3 meters away from window and door.

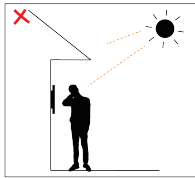

Backlight

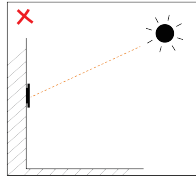

Direct sunlight

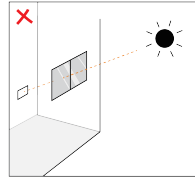

Direct sun through window

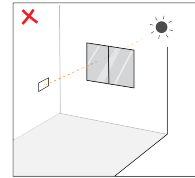

Indirect sunlight through window

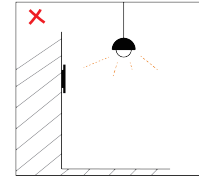

Close to light

**Attention:**

Biometric recognition product may not be considered 100% accurate in any identification application. For higher security purpose or scenario, please set up access authentication along with biometric recognition.

## Installation

### Wall-mounting Bracket Installation

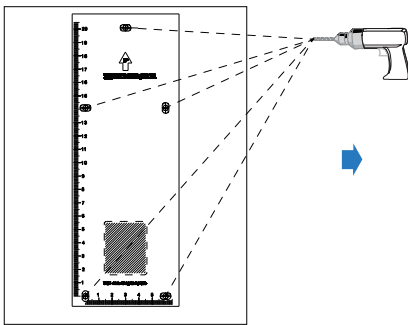

Put the wall-mounting template on wall, then according to the wall-mounting template use a hand drill to make the hole in marked holes (6 mm in diameter and 20mm in depth).

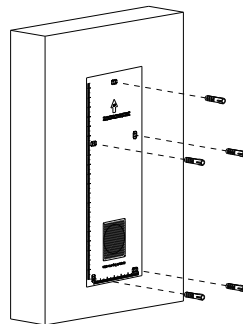

Insert the five plastic wall anchors into the drilled holes.

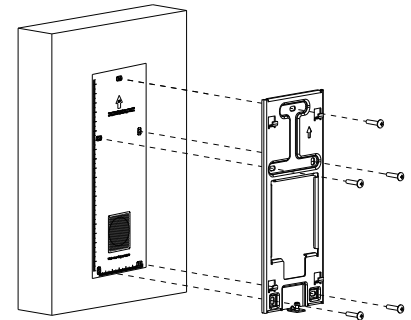

Place the wall-mounting bracket closely against the wall while lining up its five wire holes with their corresponding drilled holes. And then fasten the wall-mounting bracket on the wall by tightening five ST4x20 crosshead screws to the plastic wall anchors.

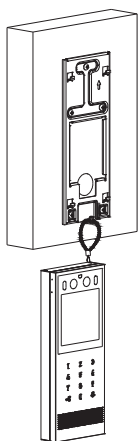

Hang the one end of the rope onto the square hanger pin on the wall-mounting bracket.

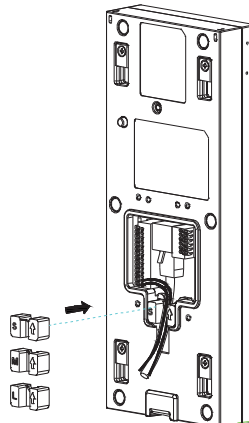

Choose a suitable size rubber plug (small, large and medium) to hold down the wires, while tearing off the adhesive sticker on the selected rubber plugs and plug them into the back cover in the position as indicated in the drawing. Connect the network cables to the corresponding interface of the mainboard, then connect the signal wire to the corresponding connection holes.

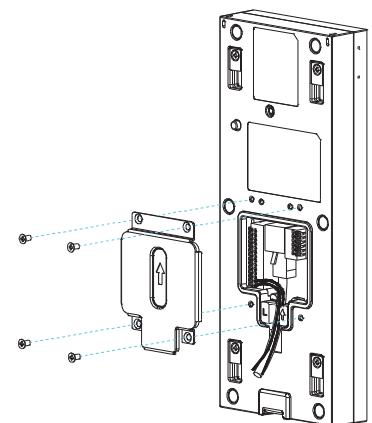

Fasten the wiring cover onto the back cover using four M3X4 crosshead screws.

Note: all the cables and wires must go through the opening at the rubber plug position.

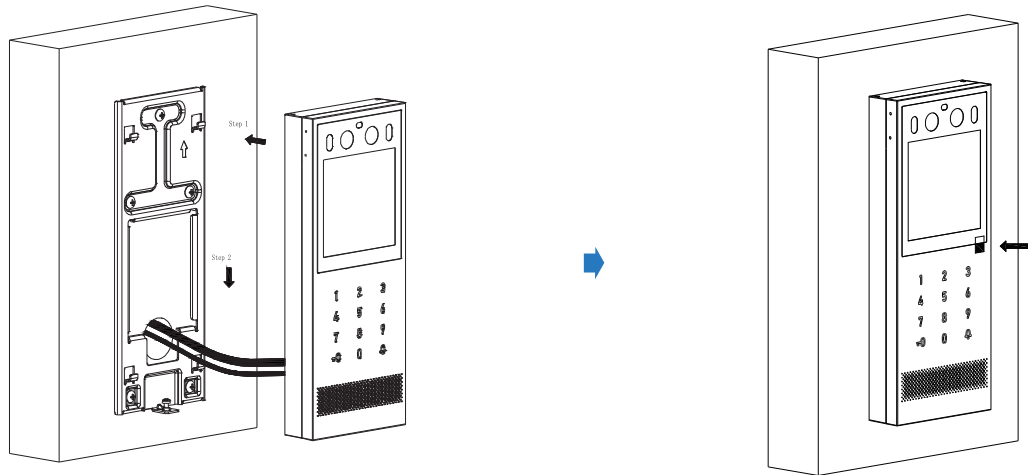

Line up the four slots at the back cover with the four hanging hooks, then hang the back over onto hooks while pressing down the whole device vertically against the hook, and let the bottom hole of the device fall down onto the hanger pin. You will hear clattering sound before installation completion.

Check if the gap surrounding the device is even. Push up the device from the device's bottom to check if the device is securely installed. And please remove the protective film.

## Device Removal

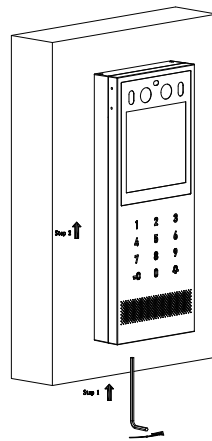

Insert the allen wrench into the left side hole at the bottom of the device, and turn the wrench 90 degrees clockwise, and push the device up vertically until the hanger pin and the device are disengaged.

## Device Wiring

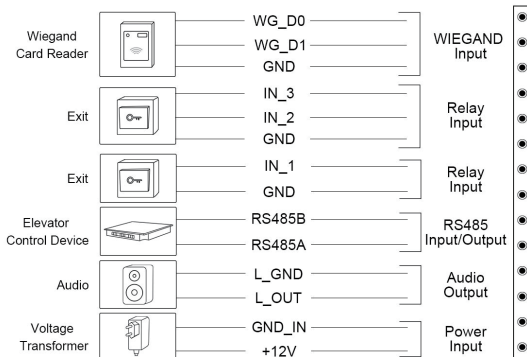

### Warning

When you connect a device containing a coil, such as a relay or an electromagnetic lock, it is necessary to protect the intercom against voltage peak while switching off the induction load. For this way of protection we recommend a diode 1 A / 200 V (included in the accessories) connected antiparallel to the device.

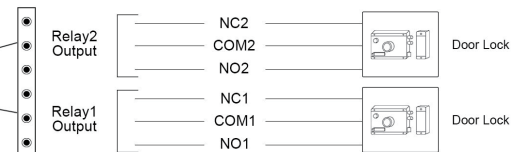
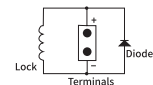

## Wire Length & AWG Table

Please follow the properly measured wire gauge/length to install device:

	20 AWG	22 AWG	24 AWG	26 AWG
12V 1A Adapter	≤20m	≤10m	\	\

## Application Network Topology

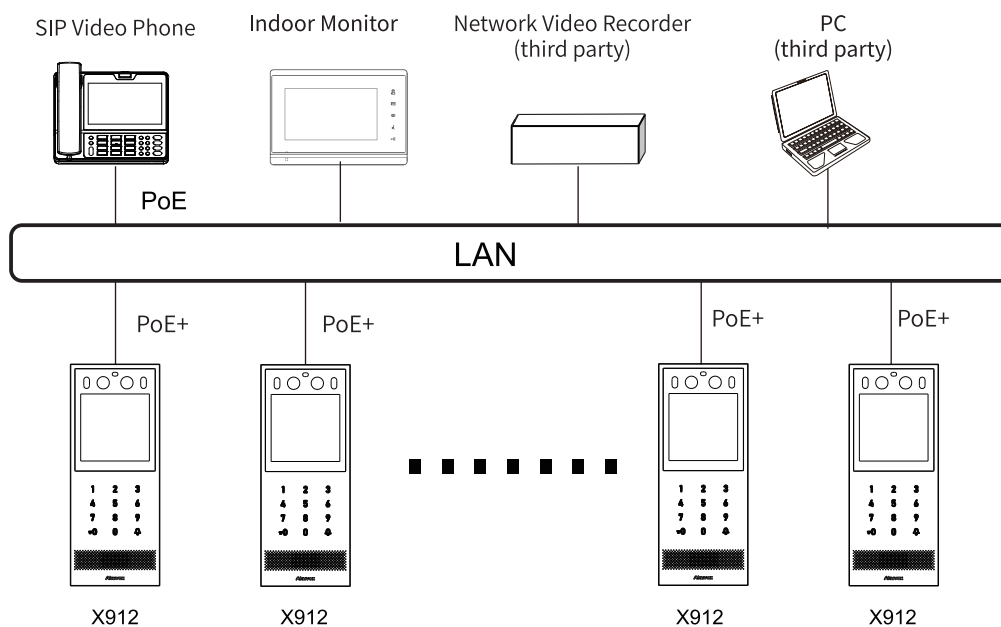

## Configuration

- 1.IP address Checking:** Press **key Icon** on the home interface or on the dial pad, then press 2396 and **bell Icon** to enter the system interface, and press **System Information** to check the device IP address. X912 uses DHCP by default.
- 2.Account Registration:** On the web interface, go to the path **Account > Basic** page to register and fill in the account information. **(Please refer to user manual for more information)**

## Operation

### Make a call:

Enter the IP or SIP number and press **bell Icon** to make a call.

### Receive a call:

X912 supports Auto Answer by default. Incoming call from indoor device will be answered automatically.

### Unlock by PIN:

Press **Key Icon** on the home interface or on the dial pad, then enter the PIN code, and press the **Key Icon** on the dial pad for the confirmation.

### Unlock by RF Card:

Place the configured RF card on the card reader area for the door access.

## Note Information



Information contained in this document is believed to be accurate and reliable at the time of printing. This document is subject to change without notice, any update to this document can be viewed on Akuvox' s website: <http://www.akuvox.com> © Copyright 2022 Akuvox Ltd. All rights reserved.